

# iHSS42

# Integrated Stepper Motors CL



## FEATURES:

- High positioning accuracy
- No stepp losses
- Cost-effective closed loop stepper motor solution
- Smooth and reliable moving at low speed
- Compact size
- Pulse Input Mode Pulse + Direction
- Variable current control technology, thus high current efficiency
- Parameters to download via RS232 to PC.
- Users can define subdivisions via external Dial-up switches or via software.
- Over-current, over-voltage and over-position protections.

## DESCRIPTION:

The iHSSXX merged stepper driver and motor together. This motor system integrates the servo control technology into the digital stepper drive perfectly. Further, this product adopts an optical encoder with high speed position sampling feedback of 50µs, once the position deviation appears, it will be fixed immediately. This product is combines the advantages of the stepper drive and servo drive, such as lower heat, less vibration, fast acceleration, and so on.

## APPLICATIONS:

iHSSXX can be used in various applications such as laser cutters, laser markers, high precision X-Y tables, labeling machines, CNC router, etc. Its unique features make the iHSV57-XX an ideal choice for applications that require low-speed smoothness by small mounting space.

## NAMING RULES iHSS stepper:

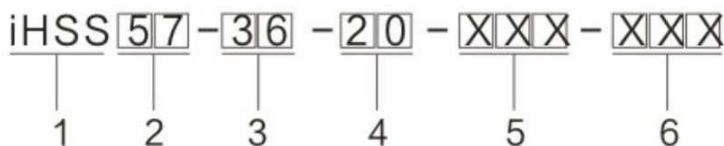

1. Integrated Closed Loop Stepper motor
2. Motor frame size: 57
3. Motor rated DC voltage: 24 means voltage is 24 V, 36 means voltage is 36 V.
4. Holding torque: 10 = 1 Nm, 20 = 2 Nm
5. Shaft length: 01 = 30 mm, 21 = 21 mm (\*)
6. Pilot diameter: no digit = 36 mm, 38 = 38.1 mm (\*\*)
7. Communication type: Blank = step and direction, 485 = RS485, CAN = CANOPEN

(\*) for iHSS42 means no digit a Shaft length of 24mm ± 1mm

(\*\*) for iHSS42 means no digit a Pilot diameter of 22mm - 0,03mm

## SPECIFICATIONS:

### Electrical Specifications:

Parameters:	Min	Typical	Max	Unit
Input Voltage	20	24	50	VDC
Output current		4.5		A
Pulse per revolution	4	-	51200	-
Pulse input frequency		-	200	kHz
Pulse Voltage	-	5	24 (with R 3 - 5 kΩ)	V
Logic Signal Current	5	10	16	mA
Isolation Resistance	100 / 500	-	-	MΩ / V DC
Insulation class		B		

# iHSS42

# Integrated Stepper Motors CL

## Motor Specifications:

Part Name:	iHSS42-24-05					Unit
Current / phase	1,2					A
Number of phases	2					-
Holding Torque	0.48					Nm
Inductance / phase	7.9					mH±20%
Resistance / phase	3					Ω ±10 %
Inertia	77					g*cm <sup>2</sup>
Weight	0.5					kg

## Operating Environment:

<b>Cooling</b>	Natural cooling or forced cooling	
<b>Operating Environment</b>	Environment	Avoid dust, oil, fog and corrosive gases
	Ambient Temperature	0 °C — 40 °C
	Humidity	40%RH — 90%RH
	Operating temperature (motor case)	110 °C max
<b>Storage Temperature</b>	-20 °C — 80 °C	

## Mechanical Specifications:

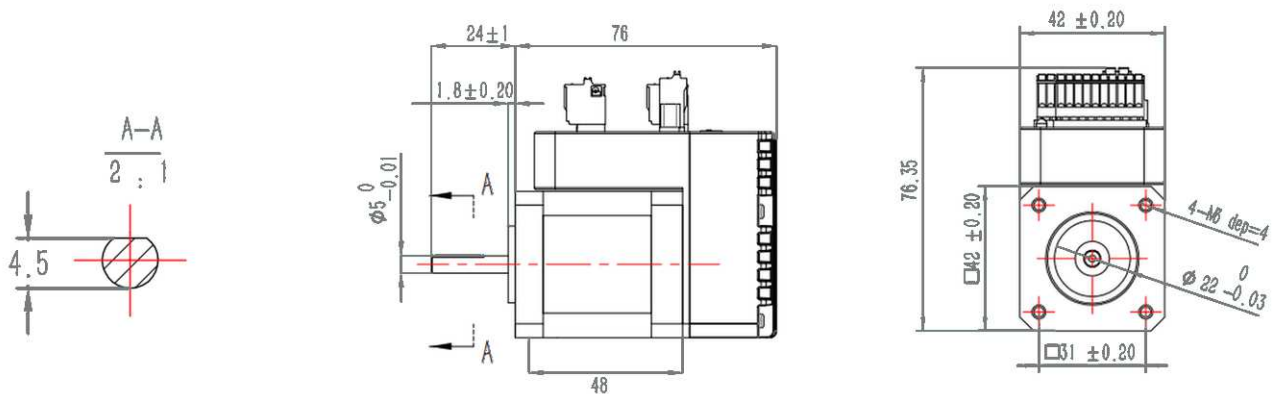

Name:	□ Square hole distance	Length of motor and drive	Shaft length	Pilot diameter
iHSS42-24-05	31 mm	76 ± 1 mm	24 ± 1 mm	22

# iHSS42

# Integrated Stepper Motors CL

## PROTECTION INDICATIONS:

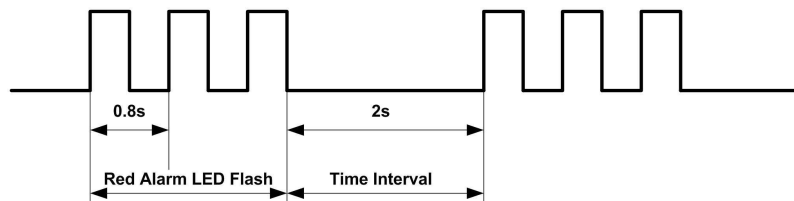

LED light flashes	Alarm description
1 time	Error occurs when the motor coil current exceeds the drive's current limit.
2 times	Voltage reference error in the drive
3 times	Parameters upload error in the drive
4 times	Error occurs when the input voltage exceeds the drive's voltage limit.
5 times	Error occurs when the actual position following error exceeds the limit.

## CONNECTORS AND PIN ASSIGNMENT

The iHSSXX have three connectors, one connector for power connections, another one for control signal connections and a third one for RS232 communication connections.

### Power Connector +VDC

Pin	Name	I/O	Description
1	DC+	I	Power Supply Input (Positive) 20 – 50 VDC; 24 V is typical. Recommended to leave reasonable reserve for voltage fluctuation and back-EMF during deceleration.
2	GND	GND	Power Ground (Negative)

### Control Signal Connector

Pin	Name	I/O	Description
1	ALM-	O	<u>Alarm Signal</u> : OC output signal, activated when one of the following protection is activated: over-voltage and over current error. They can sink or source MAX 8 mA current at 24 V, respectively 200 mW. The impedance between ALM+ and ALM- is high for normal operation and becomes low when any protection is activated.
2	ALM+	O	
3	PED-	O	<u>In-position Signal</u> : OC output signal, activated when actual motor position reaches to target position. This port can sink or source MAX 8 mA current at 24 V, respectively 200 mW. The impedance between PED+ and PED- is high for normal operation and becomes low when the target position is reached.
4	PED+	O	
5	ENA-	I	<u>Enable signal</u> : This signal is used for enabling/disabling the drive board. By default, high level (NPN control signal) for enabling the drive board and low level for disabling the drive board. It is usually left <b>UNCONNECTED (ENABLED)</b> . Please note that the PNP and Differential control signals are on the contrary, namely Low level for enabling.
6	ENA+	I	
7	DIR-	I	<u>Direction Signal</u> : In single-pulse mode, this signal has low/high voltage levels, representing two directions of motor rotation For reliable motion response, DIR signal should be ahead of PUL signal by 5µs at least. 3.5-24V for DIR-HIGH, 0-0.5V for DIR-LOW. Toggle DIP switch S6 to reverse motion direction. In case of using 24 V a Resistor 3 – 5 kΩ must be connected in line!
8	DIR+	I	
9	PUL-	I	<u>Pulse Signal</u> : In single pulse (pulse/direction) mode, this input represents pulse signal, active at each rising or falling edge (Software configurable). 3.5 – 24 V for PUL-HIGH, 0 - 0.5 V for PUL-LOW. For reliable response, pulse width should be longer than 2.5µs for 200kHz MAX input frequency. In case of using 24 V a Resistor 3 – 5 kΩ must be connected in line!
10	PUL+	I	

# iHSS42

# Integrated Stepper Motors CL

## RS232 Communication Connector

Pin	Name	Colors at the beige round cable	Colors at the grey flat cable	Description
1	NC	-	-	n.a.
2	RX	Brown-White	Yellow	Receive data
3	GND	Blue	Green	Ground.
4	TX	Blue-White	Red	Transmit data
5	VCC	-	-	Power Supply 3.3 V to HISU. Attention: For PC software use leave unconnected!

**Note1:** The RS232 communication port is not isolated. Please use an isolated power supply for the iHSSXX when the PC's serial port is not isolated.

**Note2:** Do not plug or unplug the connector when power is on.

### DIP SWITCH SETTINGS:

#### Pulses / Rev. (SW 1-SW 4)

Pulses per revolution of the iHSSXX can be configured via DIP switch S1-S4 or by the tuning software. When all S1-S4 are at "ON" positions, the drive will take the setting set by the software. In this case, a user can re-configure to any value between 4 and 51200 through software. If any bit of S1-S4 is at "OFF" position, the integrated drive board will take micro step resolution setting determined by bit positions of S1-S4. Use the following table for their resolution settings via the DIP switches.

Pulses / Revolution	SW 1	SW 2	SW 3	SW 4
<b>Software configured / Default</b>	on	on	on	on
800	off	on	on	on
1600	on	off	on	on
3200	off	off	on	on
6400	on	on	off	on
12800	off	on	off	on
25600	on	off	off	on
51200	off	off	off	on
1000	on	on	on	off
2000	off	on	on	off
4000	on	off	on	off
5000	off	off	on	off
8000	on	on	off	off
10000	off	on	off	off
20000	on	off	off	off
40000	off	off	off	off

**SW 5** is used for setting the PUL mode, "off" means the PUL mode is pulse + direction mode, "on" is double pulse mode. Double pulse mode means that a pulse signal can be connected to both the PUL and DIR inputs. The direction of rotation depends on the selected input and the position of SW 6.

**SW 6** is used for setting the running direction, "off" means CCW, while "on" means CW.

**SW 7** is used for PUL Filter Setting, "off" means Max. PUL frequency is 200 kHz, on means Max. PUL frequency is 100 kHz. Note: When the P22 parameter is 0, the pulse filtering degree is controlled by the SW7 pulse interference filtering dialing code, when set to other non-zero values, SW7 does not work.

**SW 8** is used for PUL Smoothing Setting, "off" means switch off PUL Smoothing, "on" means switch on PUL Smoothing.

# iHSS42

# Integrated Stepper Motors CL

## FINE TUNING:

Already default parameters are set by factory. Those default parameter values have been optimized. They should be good enough for most industrial applications, and there is no need to tune them. However, if you want to fine tune the iHSSXX for best performance for your applications, the tuning software is offered which allows you to adjust those parameters.

## TYPICAL CONNECTIONS:

### Connection to Common Anode:

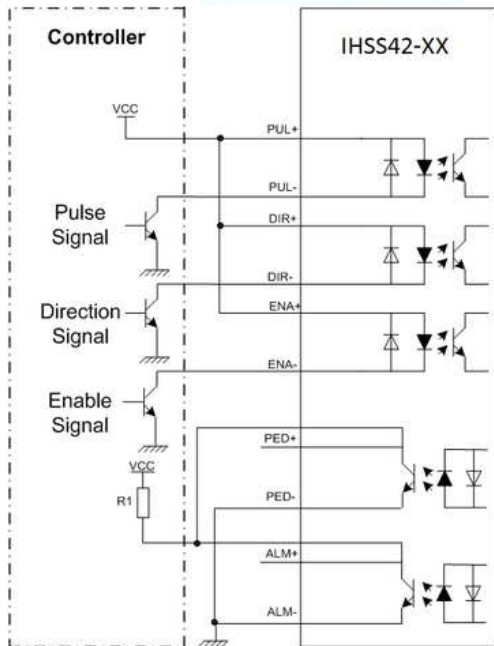

### Connection to Common Cathode:

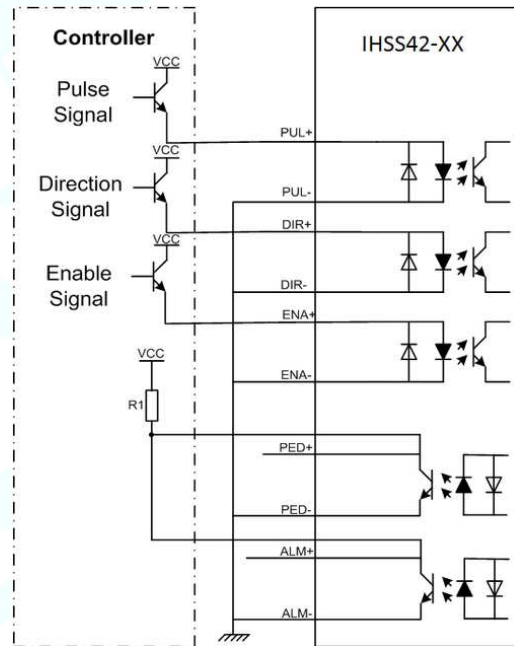

### Connection to Differential Signal:

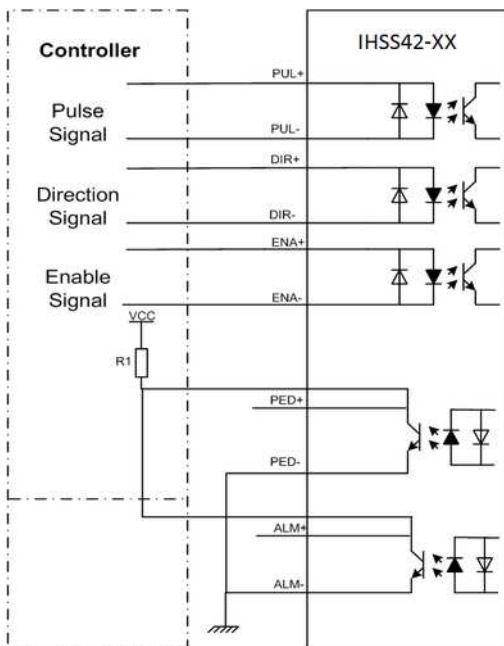

### RS232 Communication Cable Connections:

**Note1:** The RS232 communication port is not isolated. Please use a galvanic isolated power supply for the iHSS42-XX when the PC's serial port is not isolated.

**Note2:** Do not plug or unplug the connector when power is on.

	Symbol	Definition	Remark
NC	○     ▷	NC	Reserved
RX	○     ▷	RX	Receive Data
GND	○     ▷	GND	Power Ground
TX	○     ▷	TX	Transmit Data
VCC	○     ▷	+5V	Power Supply to HISU